

Packaging Specifications of Tape and Reel for SOT-89

1. The method of packaging and dimension are shown as below figure. (Dimension in mm)

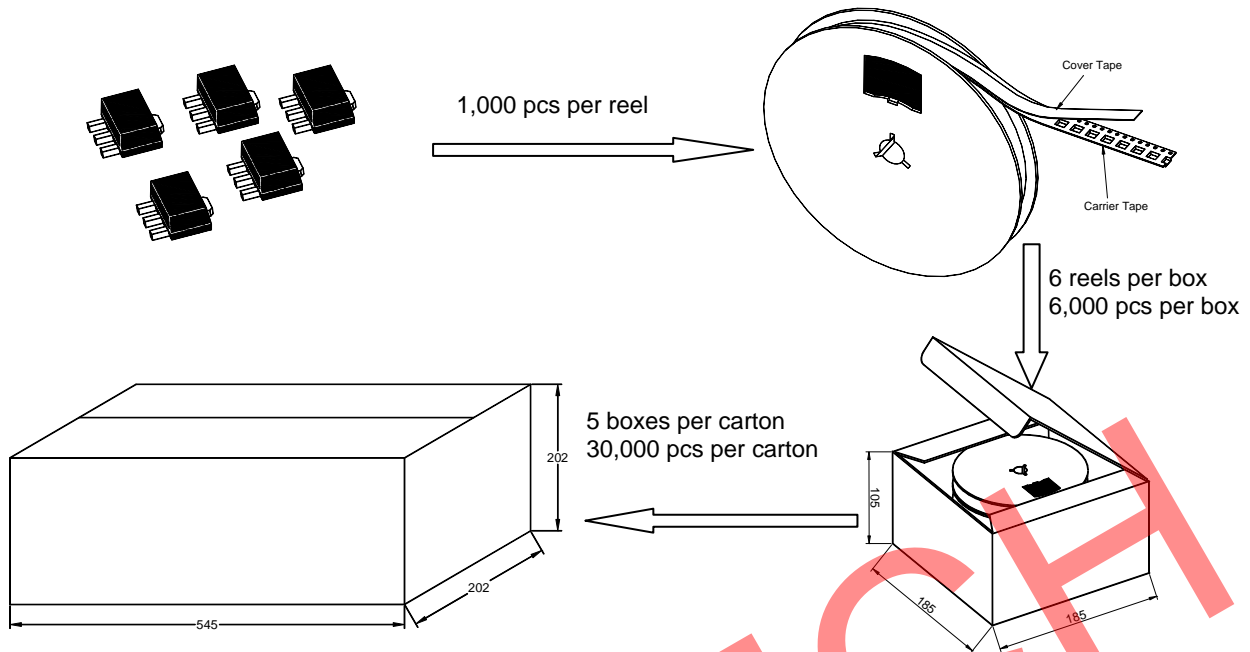

2. Tape and reel data (Units: mm)

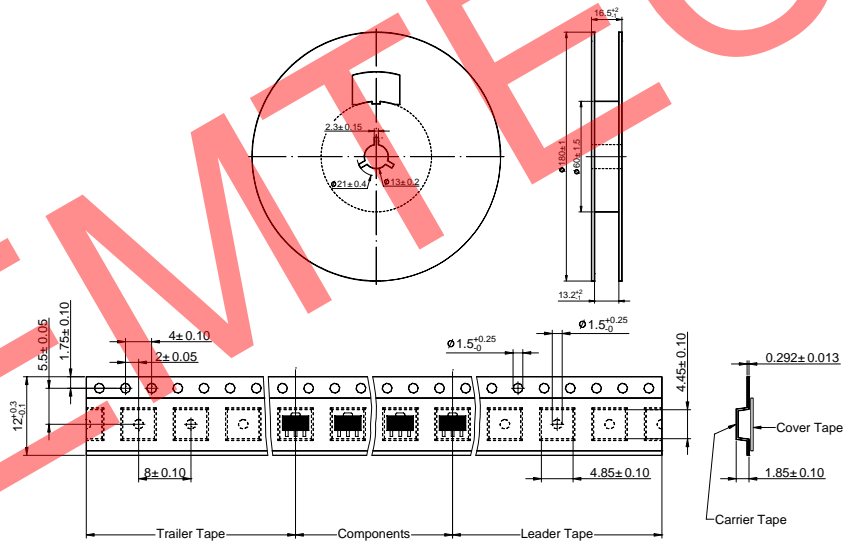

3. Label

3.1 The information of inner box label must be listed: (Description of a sample label)

- | | | |
|-------|---------------------|---------------------------------|
| 3.1.1 | TYPE ST2SB772PU | means (Product) TYPE (Part No.) |
| 3.1.2 | QTY 1,000 PCS | means (Product) Quantity (QTY) |
| 3.1.3 | D/C AS1A0K08173753 | means Dice Lot No./ Code (D/C) |
| 3.1.4 | P/C TCB80067-001603 | means Production Code (P/C) |
| 3.1.5 | RMK10822 | means Manufacturing Date (RMK) |

3.2 The information of carton label must be listed;

- 3.2.1 TYPE
- 3.2.2 QTY

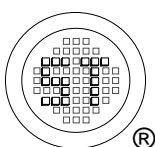

SEMTECH ELECTRONICS LTD.
Subsidiary of Sino-Tech International (BVI) Limited



Packaging Specifications of Tape and 7" Reel for SOT-89

1. The method of packaging and dimension are shown as below figure. (Dimension in mm)

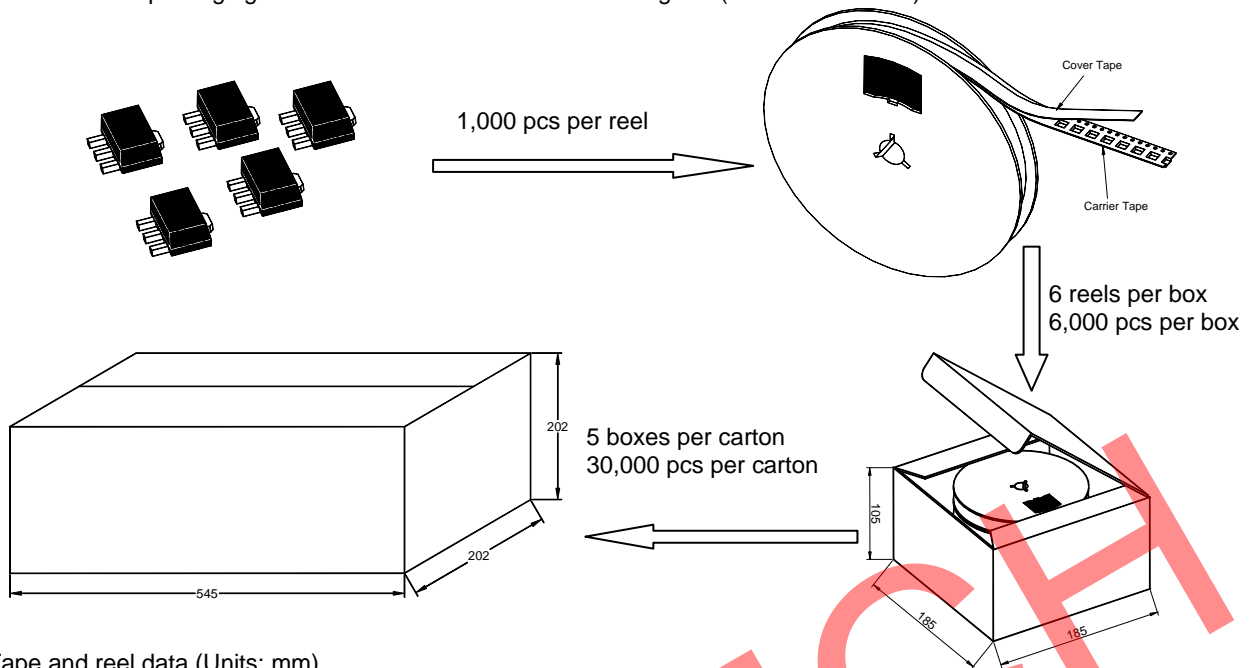

2. Tape and reel data (Units: mm)

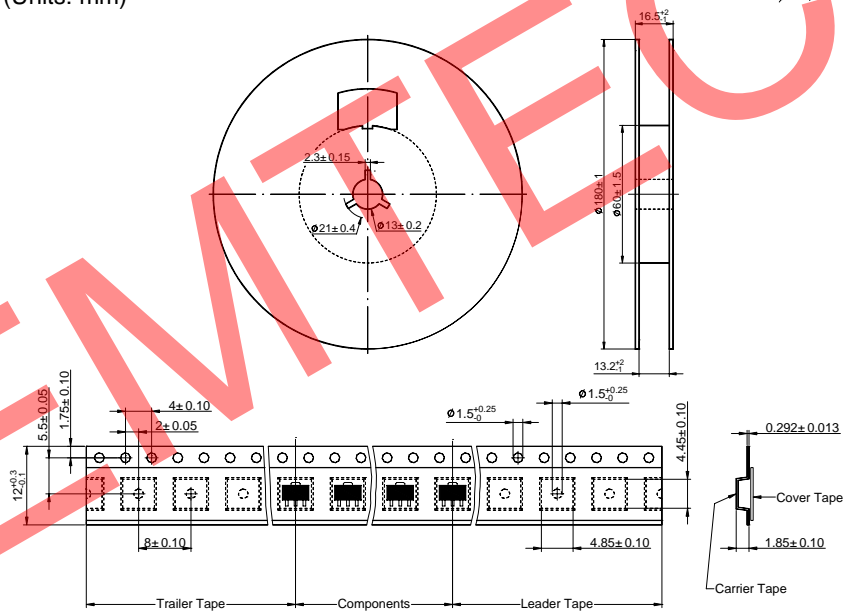

3. Label

3.1 The information of inner box label must be listed: (Description of a sample label)

- | | | |
|-------|---------------------|---------------------------------|
| 3.1.1 | TYPE ST2SB772PU | means (Product) TYPE (Part No.) |
| 3.1.2 | QTY 1,000 PCS | means (Product) Quantity (QTY) |
| 3.1.3 | D/C AS1A0K08173753 | means Dice Lot No./ Code (D/C) |
| 3.1.4 | P/C TCB80067-001603 | means Production Code (P/C) |
| 3.1.5 | RMK10822 | means Manufacturing Date (RMK) |

3.2 The information of carton label must be listed;

- 3.2.1 TYPE
- 3.2.2 QTY

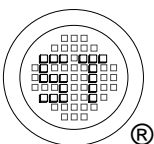

SEMTECH ELECTRONICS LTD.
Subsidiary of Sino-Tech International (BVI) Limited



Packaging Specifications of Tape and 13" Reel for SOT-89

1. The method of packaging and dimension are shown as below figure. (Dimension in mm)

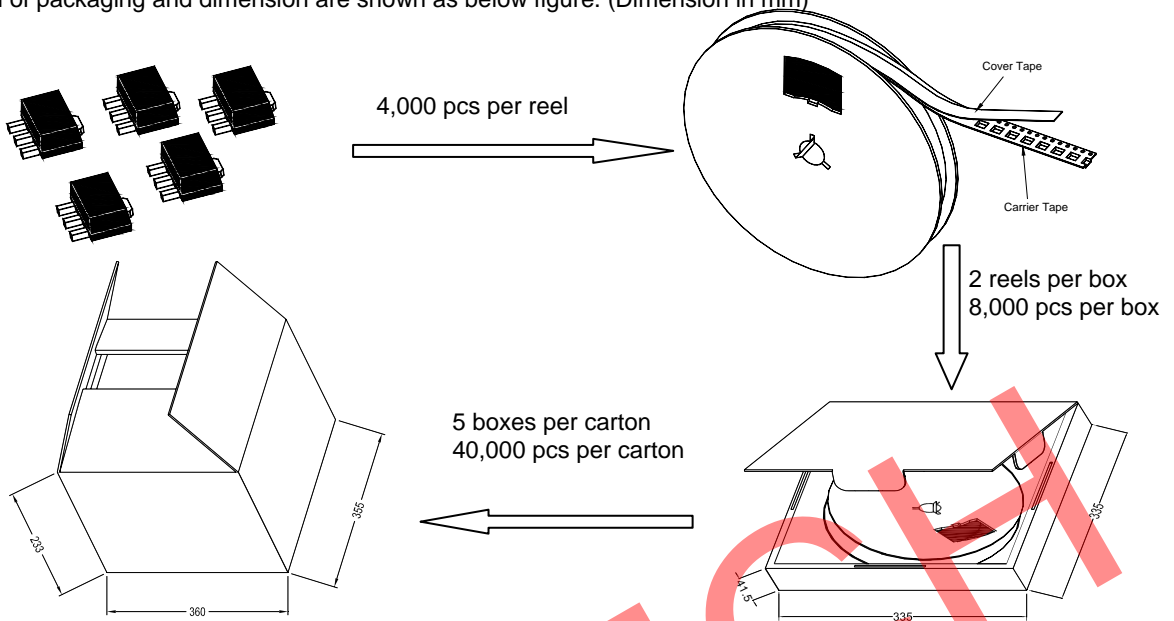

2. Tape and reel data (Units: mm)

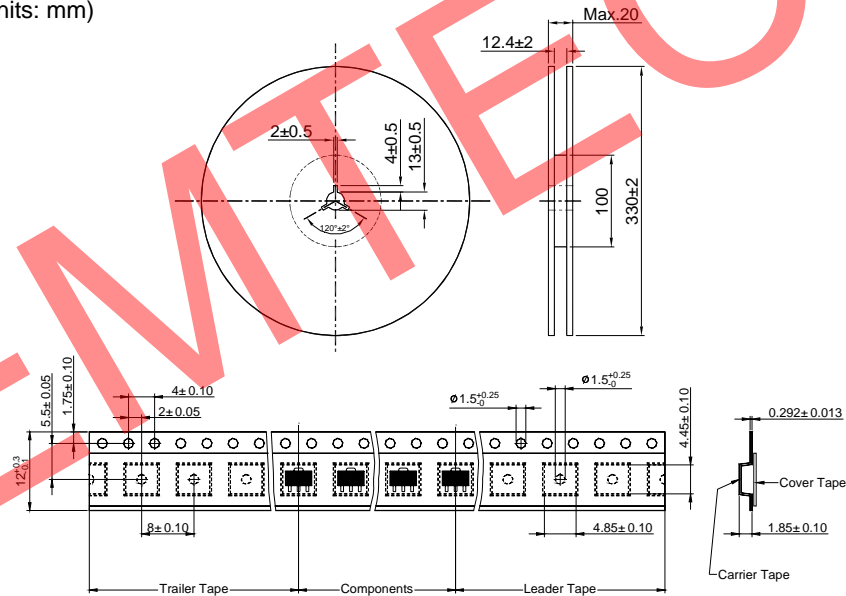

3. Label

3.1 The information of inner box label must be listed: (Description of a sample label)

- | | | |
|-------|-----------------------------|---------------------------------|
| 3.1.1 | TYPE ST2SA1666YU-HAF | means (Product) TYPE (Part No.) |
| 3.1.2 | QTY 4,000 PCS | means (Product) Quantity (QTY) |
| 3.1.3 | D/C TT1J2L0705L0008 | means Dice Lot No./ Code (D/C) |
| 3.1.4 | P/C TCC80207A-002692 | means Production Code (P/C) |
| 3.1.5 | RMK30422 | means Manufacturing Date (RMK) |

3.2 The information of carton label must be listed;

- 3.2.1 TYPE
- 3.2.2 QTY

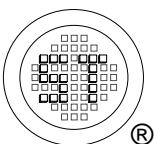

SEMTECH ELECTRONICS LTD.
Subsidiary of Sino-Tech International (BVI) Limited

