

MMBTRA301E...MMBTRA306E

PNP Silicon Epitaxial Planar Transistor

for switching and interface circuit and drive circuit applications

Features

- With built-in bias resistors
- Simplify circuit design
- Reduce a quantity of parts and manufacturing process

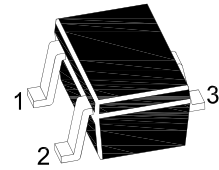
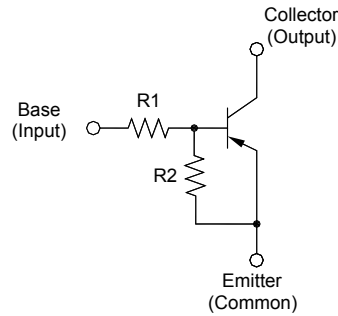

1.Base 2.Emitter 3.Collector
SOT-523 Plastic Package

Resistor Values

Type	R1 (KΩ)	R2 (KΩ)
MMBTRA301E	4.7	4.7
MMBTRA302E	10	10
MMBTRA303E	22	22
MMBTRA304E	47	47
MMBTRA305E	2.2	47
MMBTRA306E	4.7	47

Absolute Maximum Ratings ($T_a = 25^\circ\text{C}$)

Parameter	Symbol	Value	Unit
Output Voltage	$-V_o$	50	V
Input Voltage	$-V_i$	MMBTRA301E	20, -10
		MMBTRA302E	30, -10
		MMBTRA303E	40, -10
		MMBTRA304E	40, -10
		MMBTRA305E	12, -5
		MMBTRA306E	20, -5
Output Current	$-I_o$	100	mA
Total Power Dissipation	P_{tot}	100	mW
Junction Temperature	T_j	150	$^\circ\text{C}$
Storage Temperature Range	T_{stg}	- 55 to + 150	$^\circ\text{C}$

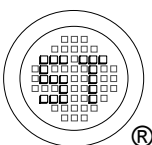

SEMTECH ELECTRONICS LTD.
Subsidiary of Sino-Tech International (BVI) Limited



MMBTRA301E...MMBTRA306E

Characteristics at $T_a = 25\text{ }^\circ\text{C}$

Parameter	Symbol	Min.	Typ.	Max.	Unit
DC Current Gain at $-V_o = 5\text{ V}$, $-I_o = 10\text{ mA}$	MMBTRA301E MMBTRA302E MMBTRA303E MMBTRA304E MMBTRA305E MMBTRA306E	30 50 70 80 80 80	- - - - - -	- - - - - -	- - - - - -
Output Cutoff Current at $-V_o = 50\text{ V}$		-	-	500	nA
Input Current at $-V_i = 5\text{ V}$	MMBTRA301E MMBTRA302E MMBTRA303E MMBTRA304E MMBTRA305E MMBTRA306E	- - - - - -	- - - - - -	1.8 0.88 0.36 0.18 3.6 1.8	mA
Output Voltage at $-I_o = 10\text{ mA}$, $-I_i = 0.5\text{ mA}$		-	-	0.3	V
Input Voltage (ON) at $-V_o = 0.2\text{ V}$, $-I_o = 5\text{ mA}$	MMBTRA301E MMBTRA302E MMBTRA303E MMBTRA304E MMBTRA305E MMBTRA306E	- - - - - -	- - - - - -	2 2.4 3 5 1.1 1.3	V
Input Voltage (OFF) at $-V_o = 5\text{ V}$, $-I_o = 0.1\text{ mA}$	MMBTRA301E~304E MMBTRA305E~306E	1 0.5	- -	- -	V
Transition Frequency at $-V_o = 10\text{ V}$, $-I_o = 5\text{ mA}$		-	200	-	MHz

¹⁾ Characteristic of transistor only.

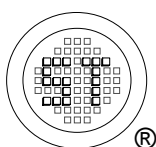

SEMTECH ELECTRONICS LTD.
Subsidiary of Sino-Tech International (BVI) Limited



Dated : 08/11/2010 Rev:01

MMBTRA301E...MMBTRA306E

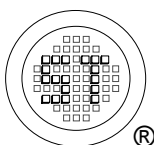
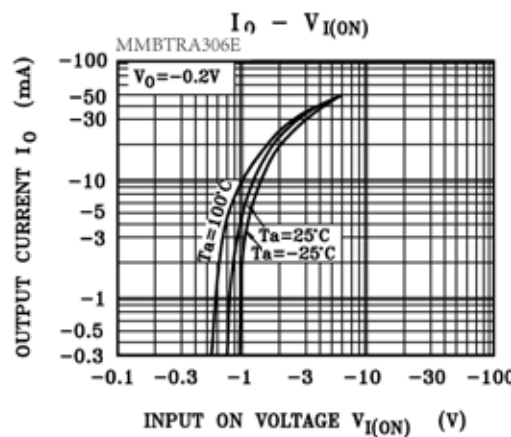
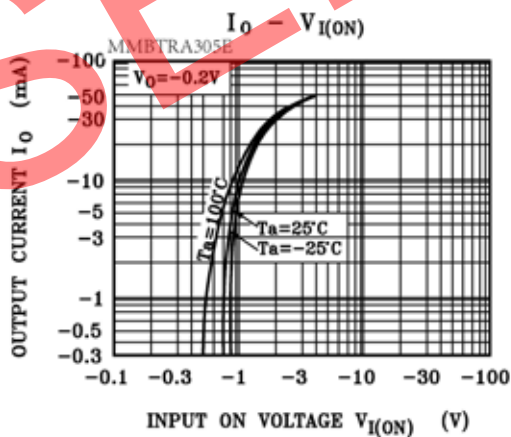
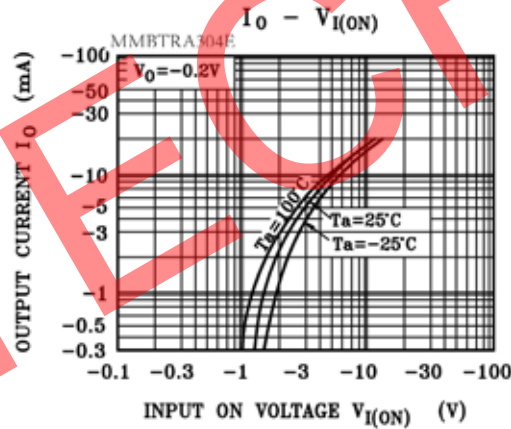
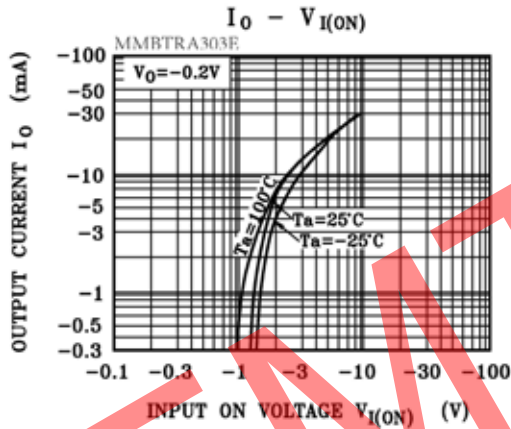
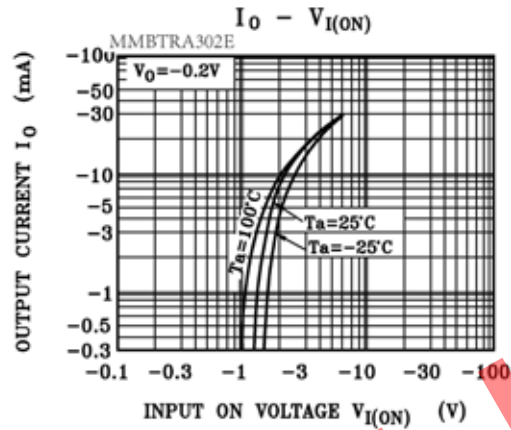
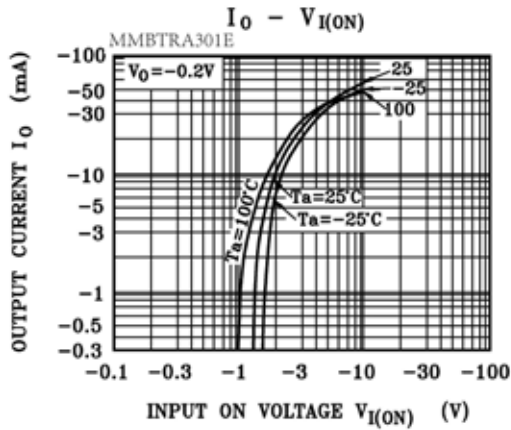

SEMTECH ELECTRONICS LTD.
 Subsidiary of Sino-Tech International (BVI) Limited



MMBTRA301E...MMBTRA306E

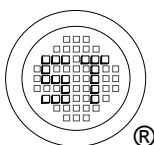
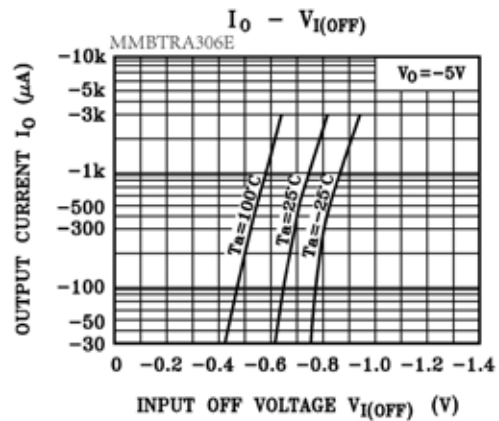
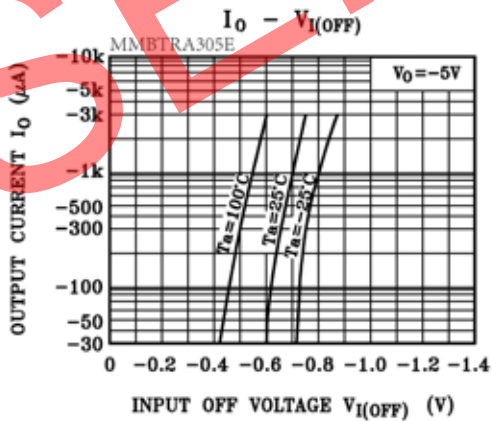
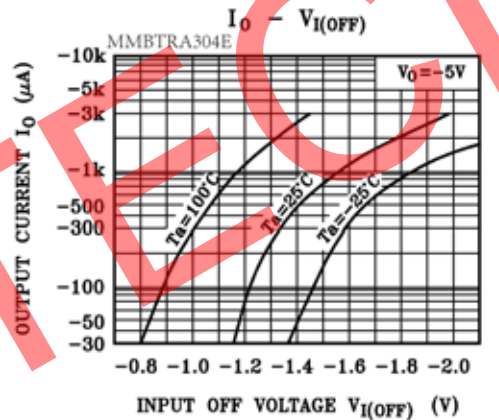
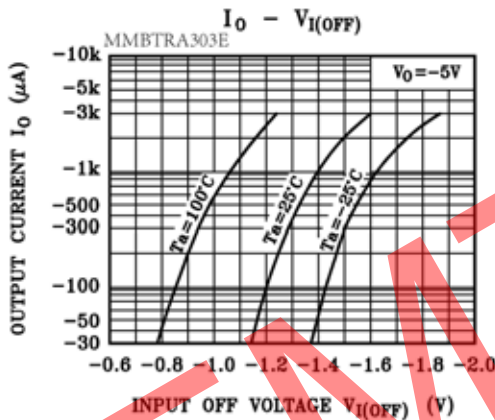
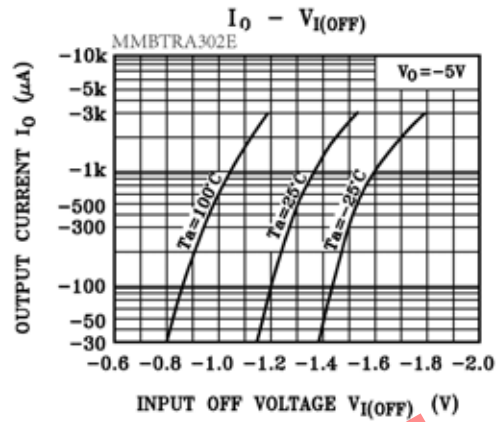
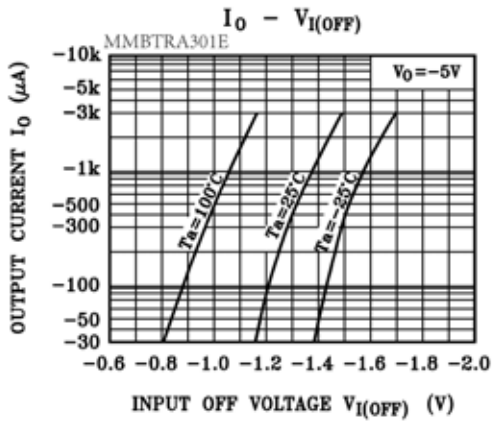

SEMTECH ELECTRONICS LTD.
 Subsidiary of Sino-Tech International (BVI) Limited



MMBTRA301E...MMBTRA306E

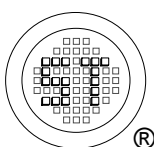
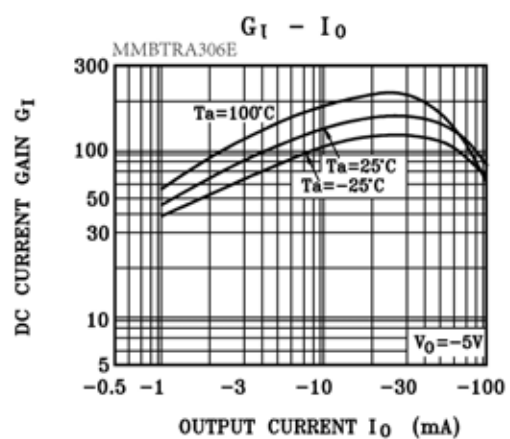
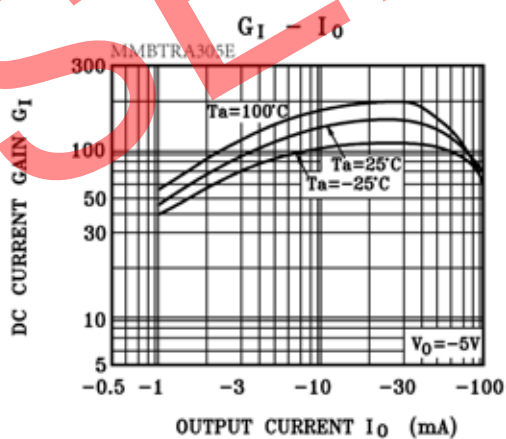
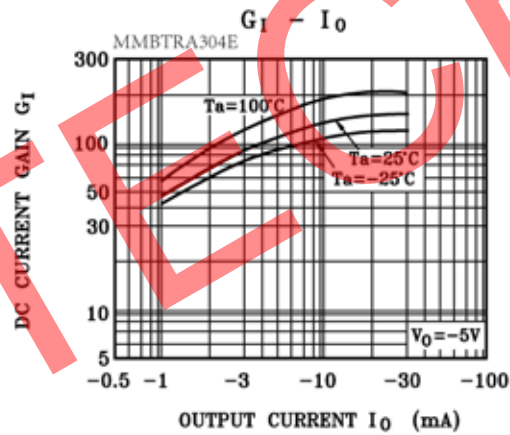
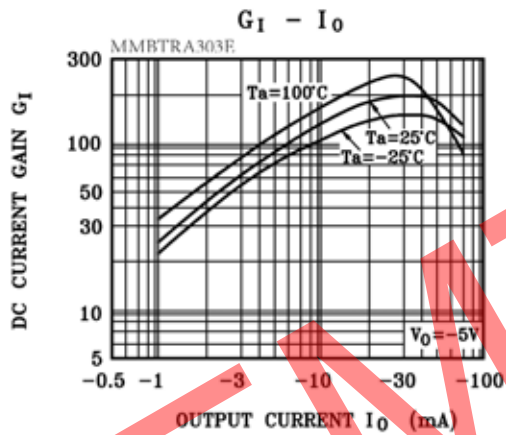
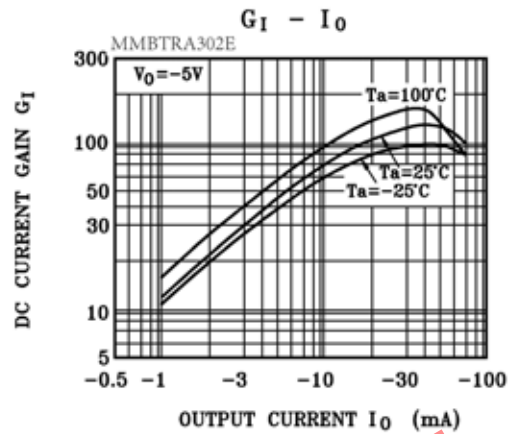
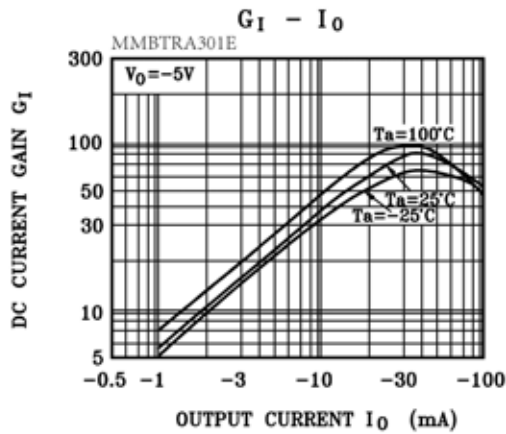

SEMTECH ELECTRONICS LTD.
Subsidiary of Sino-Tech International (BVI) Limited

