

# ST 2SA1661U

## PNP Silicon Epitaxial Planar Transistor

for high current application

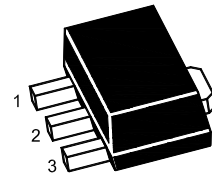

1.Base 2.Collector 3.Emitter  
SOT-89 Plastic Package

### Absolute Maximum Ratings ( $T_a = 25\text{ }^\circ\text{C}$ )

Parameter	Symbol	Value	Unit
Collector Base Voltage	$-V_{CBO}$	120	V
Collector Emitter Voltage	$-V_{CEO}$	120	V
Emitter Base Voltage	$-V_{EBO}$	5	V
Collector Current	$-I_C$	800	mA
Base Current	$-I_B$	160	mA
Total Power Dissipation	$P_{tot}$	0.5 1 <sup>1)</sup>	W
Junction Temperature	$T_j$	150	$^\circ\text{C}$
Storage Temperature Range	$T_{stg}$	- 55 to + 150	$^\circ\text{C}$

<sup>1)</sup> When mounted on a 250 mm<sup>2</sup> X 0.8 t ceramic substrate.

### Characteristics at $T_a = 25\text{ }^\circ\text{C}$

Parameter	Symbol	Min.	Typ.	Max.	Unit	
DC Current Gain at $-V_{CE} = 5\text{ V}$ , $-I_C = 100\text{ mA}$	Current Gain Group O	$h_{FE}$	80	-	160	-
	Y	$h_{FE}$	120	-	240	-
Collector Base Cutoff Current at $-V_{CB} = 120\text{ V}$	$-I_{CBO}$	-	-	100	nA	
Emitter Base Cutoff Current at $-V_{EB} = 5\text{ V}$	$-I_{EBO}$	-	-	100	nA	
Collector Emitter Breakdown Voltage at $-I_C = 10\text{ mA}$	$-V_{(BR)CEO}$	120	-	-	V	
Emitter Base Breakdown Voltage at $-I_E = 1\text{ mA}$	$-V_{(BR)EBO}$	5	-	-	V	
Collector Emitter Saturation Voltage at $-I_C = 500\text{ mA}$ , $-I_B = 50\text{ mA}$	$-V_{CE(sat)}$	-	-	1	V	
Base Emitter on Voltage at $-V_{CE} = 5\text{ V}$ , $-I_C = 500\text{ mA}$	$-V_{BE(on)}$	-	-	1	V	
Transition Frequency at $-V_{CE} = 5\text{ V}$ , $-I_C = 100\text{ mA}$	$f_T$	-	120	-	MHz	
Collector Output Capacitance at $-V_{CB} = 10\text{ V}$ , $f = 1\text{ MHz}$	$C_{ob}$	-	-	30	pF	

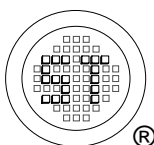

**SEMTECH ELECTRONICS LTD.**  
Subsidiary of Sino-Tech International (BVI) Limited



Dated : 06/12/2010 Rev:01

# ST 2SA1661U

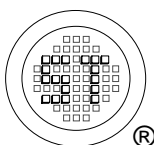
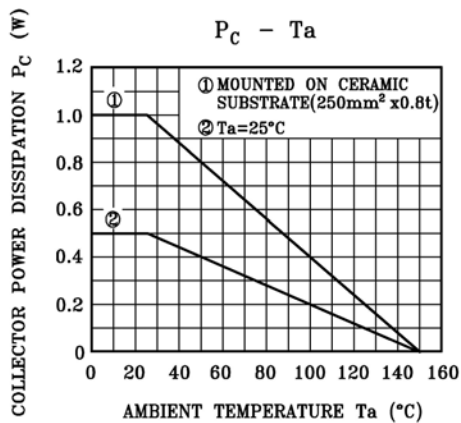
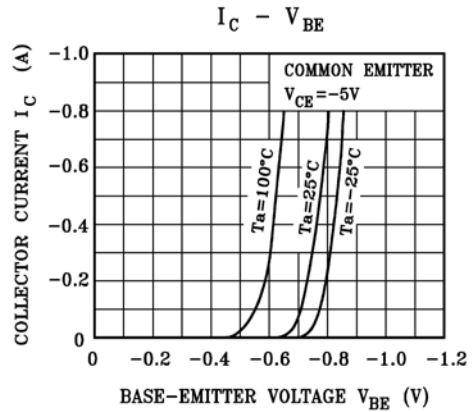
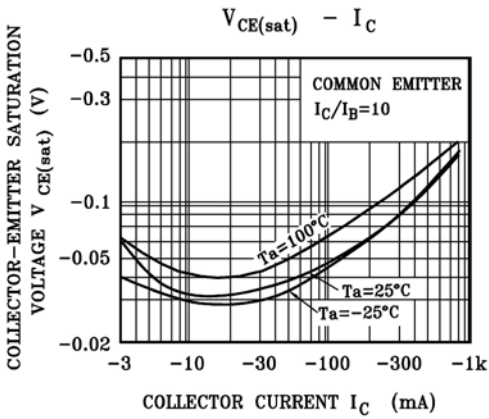
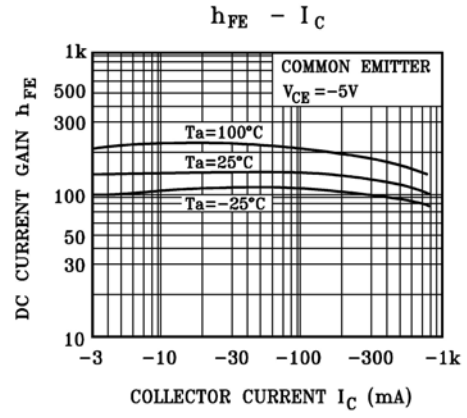
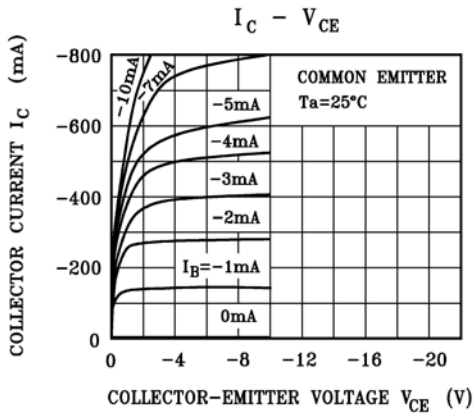

**SEMTECH ELECTRONICS LTD.**  
Subsidiary of Sino-Tech International (BVI) Limited



# ST 2SA1661U

## SOT-89 PACKAGE OUTLINE

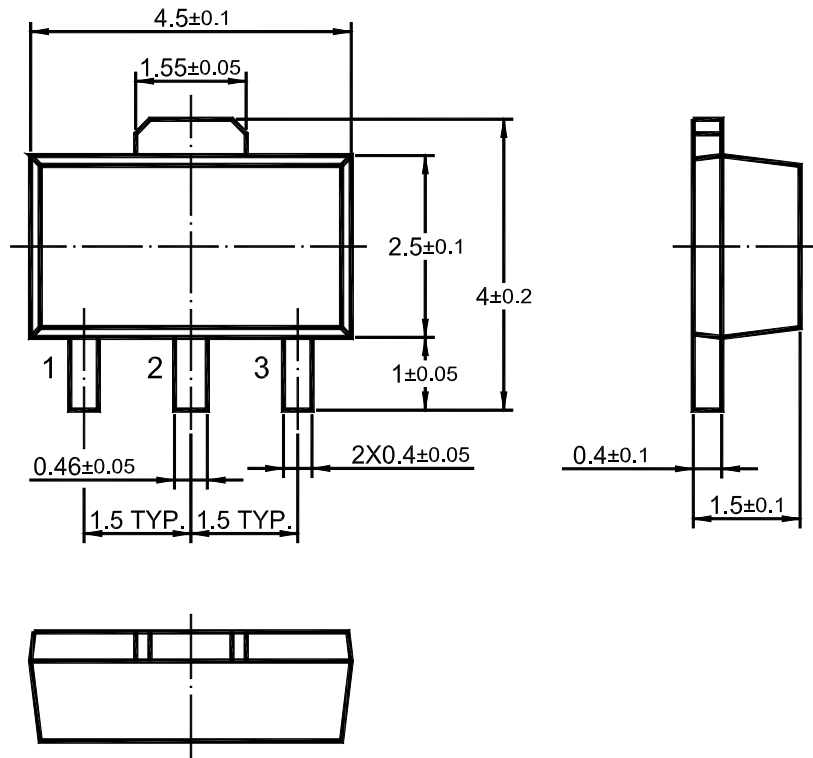

Dimensions in mm

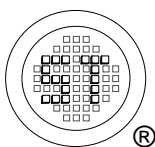

**SEMTECH ELECTRONICS LTD.**  
Subsidiary of Sino-Tech International (BVI) Limited



Dated : 06/12/2010 Rev:01