

SEMTECH ELECTRONICS LTD.
Subsidiary of Sino-Tech International (BVI) Limited

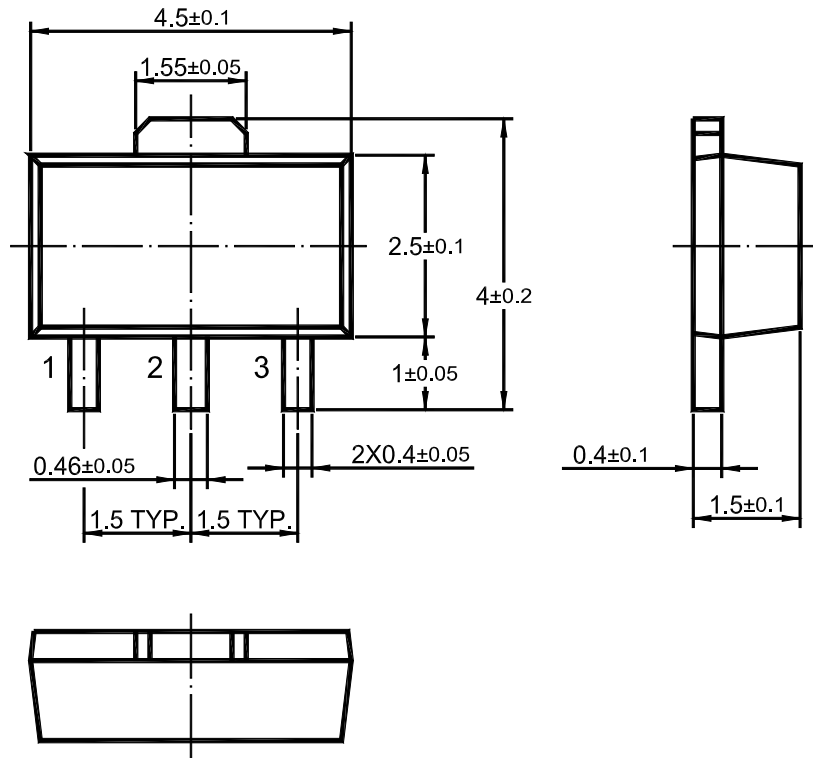

ST 2SD965U

SOT-89 PACKAGE OUTLINE



Dimensions in mm

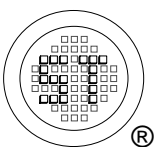

SEMTECH ELECTRONICS LTD.
Subsidiary of Sino-Tech International (BVI) Limited



Dated : 22/05/2006