

# ST 2SA1666U

## PNP Silicon Epitaxial Planar Transistor

for high current application

The transistor is subdivided into two groups, O and Y, according to its DC current gain.

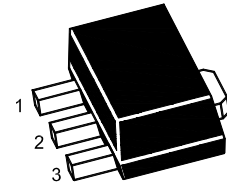

1.Base 2.Collector 3.Emitter  
SOT-89 Plastic Package

### Absolute Maximum Ratings ( $T_a = 25\text{ }^\circ\text{C}$ )

Parameter	Symbol	Value	Unit
Collector Base Voltage	$-V_{CBO}$	50	V
Collector Emitter Voltage	$-V_{CEO}$	50	V
Emitter Base Voltage	$-V_{EBO}$	5	V
Collector Current	$-I_C$	2	A
Base Current	$-I_B$	0.4	A
Total Power Dissipation	$P_{tot}$	0.5 1 <sup>1)</sup>	W
Junction Temperature	$T_j$	150	$^\circ\text{C}$
Storage Temperature Range	$T_{stg}$	- 55 to + 150	$^\circ\text{C}$

<sup>1)</sup> When mounted on a 250 mm<sup>2</sup> X 0.8 t ceramic substrate.

### Characteristics at $T_a = 25\text{ }^\circ\text{C}$

Parameter	Symbol	Min.	Typ.	Max.	Unit	
DC Current Gain at $-V_{CE} = 2\text{ V}$ , $-I_C = 500\text{ mA}$  at $-V_{CE} = 2\text{ V}$ , $-I_C = 1.5\text{ A}$	Current Gain Group O	$h_{FE}$	70	-	140	-
	Y	$h_{FE}$	120	-	240	-
	$h_{FE}$	40	-	-	-	-
Collector Base Cutoff Current at $-V_{CB} = 50\text{ V}$	$-I_{CBO}$	-	-	100	nA	
Emitter Base Cutoff Current at $-V_{EB} = 5\text{ V}$	$-I_{EBO}$	-	-	100	nA	
Collector Emitter Breakdown Voltage at $-I_C = 10\text{ mA}$	$-V_{(BR)CEO}$	50	-	-	V	
Collector Emitter Saturation Voltage at $-I_C = 1\text{ A}$ , $-I_B = 50\text{ mA}$	$-V_{CE(sat)}$	-	-	0.5	V	
Base Emitter Saturation Voltage at $-I_C = 1\text{ A}$ , $-I_B = 50\text{ mA}$	$-V_{BE(sat)}$	-	-	1.2	V	
Transition Frequency at $-V_{CE} = 2\text{ V}$ , $-I_C = 500\text{ mA}$	$f_T$	-	120	-	MHz	
Collector Output Capacitance at $-V_{CB} = 10\text{ V}$ , $f = 1\text{ MHz}$	$C_{ob}$	-	40	-	pF	

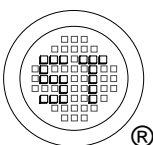

**SEMTECH ELECTRONICS LTD.**  
Subsidiary of Sino-Tech International (BVI) Limited



Dated : 23/06/2010 Rev:01

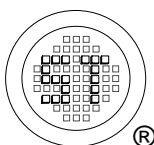
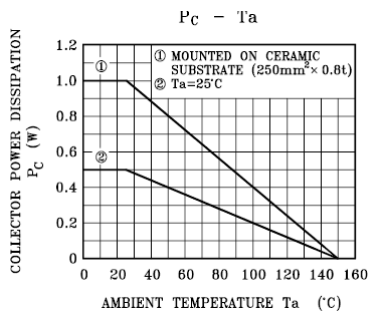
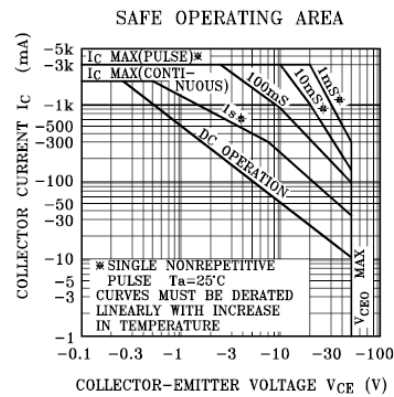
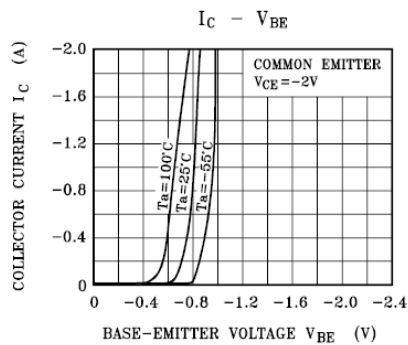
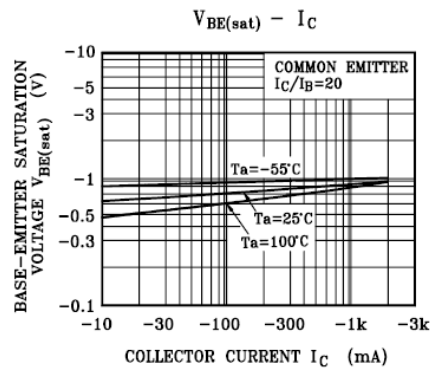
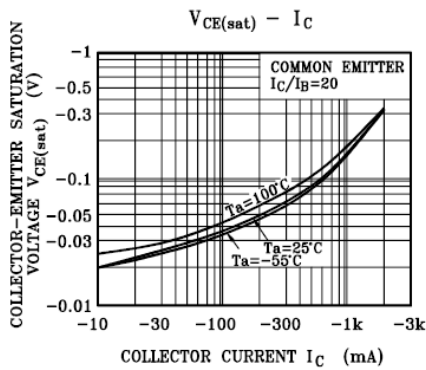
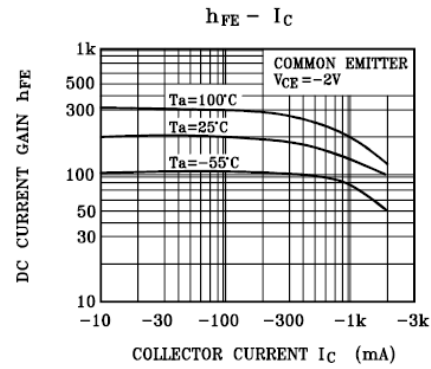
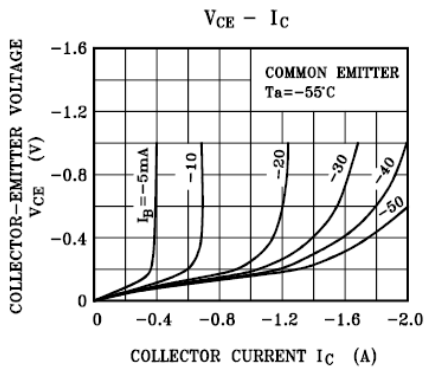
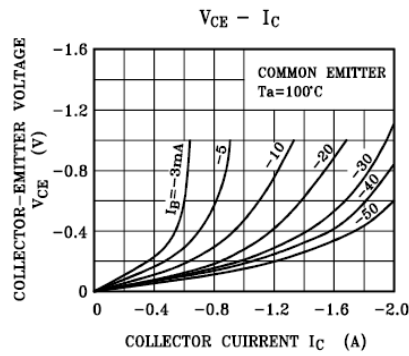
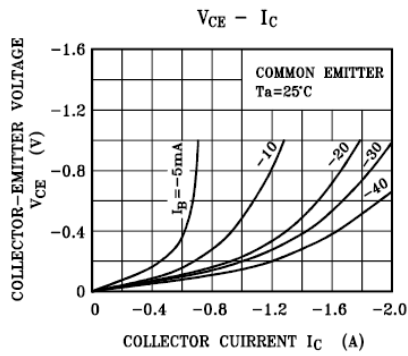

**SEMTECH ELECTRONICS LTD.**  
Subsidiary of Sino-Tech International (BVI) Limited



# ST 2SA1666U

## SOT-89 PACKAGE OUTLINE

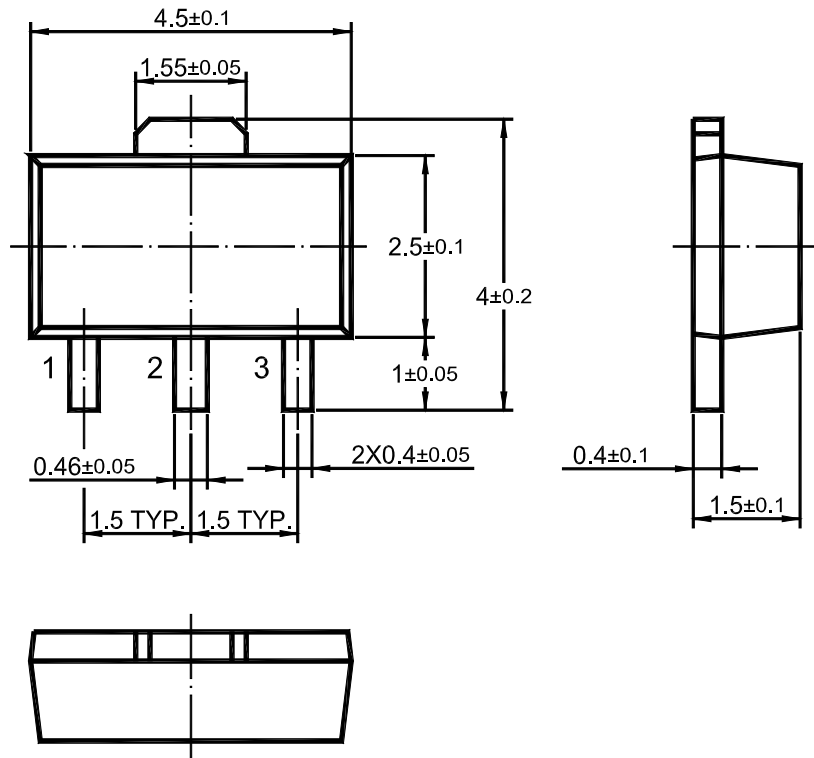

Dimensions in mm

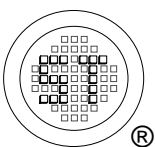

**SEMTECH ELECTRONICS LTD.**  
Subsidiary of Sino-Tech International (BVI) Limited



Dated : 23/06/2010 Rev:01