

# ST 2SC4375U

## NPN Silicon Epitaxial Planar Transistor

High current application

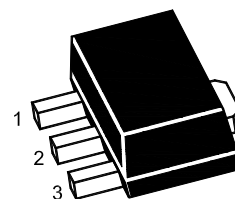

1.Base 2.Collector 3.Emitter  
SOT-89 Plastic Package

### Absolute Maximum Ratings ( $T_a = 25\text{ }^\circ\text{C}$ )

Parameter	Symbol	Value	Unit
Collector Base Voltage	$V_{CBO}$	30	V
Collector Emitter Voltage	$V_{CEO}$	30	V
Emitter Base Voltage	$V_{EBO}$	5	V
Collector Current	$I_C$	1.5	A
Total Power Dissipation	$P_{tot}$	0.5 1 <sup>1)</sup>	W
Junction Temperature	$T_J$	150	$^\circ\text{C}$
Storage Temperature Range	$T_{Stg}$	- 55 to + 150	$^\circ\text{C}$

<sup>1)</sup> When mounted on a 250 mm<sup>2</sup> X 0.8 t ceramic substrate.

### Characteristics at $T_a = 25\text{ }^\circ\text{C}$

Parameter	Symbol	Min.	Typ.	Max.	Unit	
DC Current Gain at $V_{CE} = 2\text{ V}$ , $I_C = 500\text{ mA}$	Current Gain Group O	$h_{FE}$	100	-	200	-
	Y	$h_{FE}$	160	-	320	-
Collector Base Breakdown Voltage at $I_C = 1\text{ mA}$	$V_{(BR)CBO}$	30	-	-	V	
Collector Emitter Breakdown Voltage at $I_C = 10\text{ mA}$	$V_{(BR)CEO}$	30	-	-	V	
Emitter Base Breakdown Voltage at $I_E = 1\text{ mA}$	$V_{(BR)EBO}$	5	-	-	V	
Collector Cutoff Current at $V_{CB} = 30\text{ V}$	$I_{CBO}$	-	-	100	nA	
Emitter Cutoff Current at $V_{EB} = 5\text{ V}$	$I_{EBO}$	-	-	100	nA	
Collector Emitter Saturation Voltage at $I_C = 1.5\text{ A}$ , $I_B = 30\text{ mA}$	$V_{CE(sat)}$	-	-	2	V	
Base Emitter Voltage at $V_{CE} = 2\text{ V}$ , $I_C = 500\text{ mA}$	$V_{BE}$	-	-	1	V	
Transition Frequency at $V_{CE} = 2\text{ V}$ , $I_C = 500\text{ mA}$	$f_T$	-	120	-	MHz	
Collector Output Capacitance at $V_{CB} = 10\text{ V}$ , $f = 1\text{ MHz}$	$C_{ob}$	-	-	40	pF	

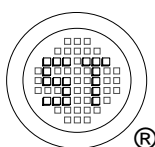

**SEMTECH ELECTRONICS LTD.**  
Subsidiary of Sino-Tech International (BVI) Limited



Dated : 17/04/2007

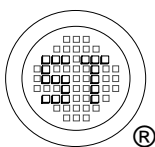
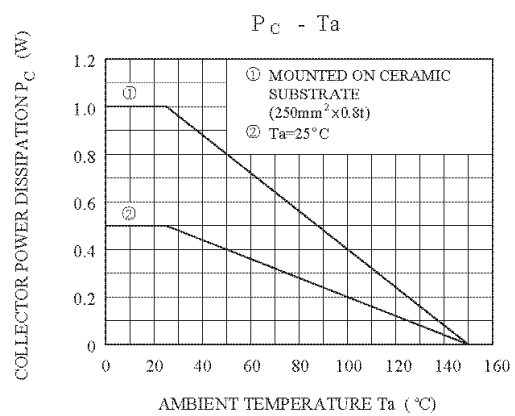
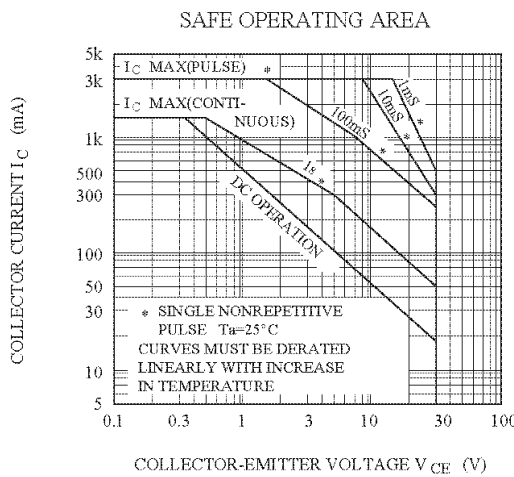
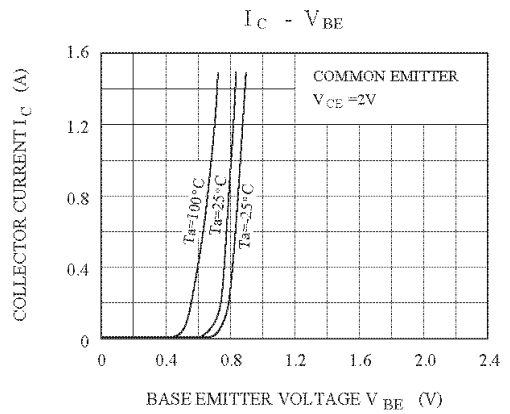
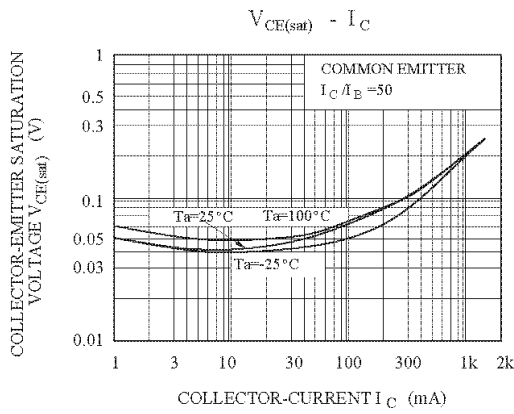
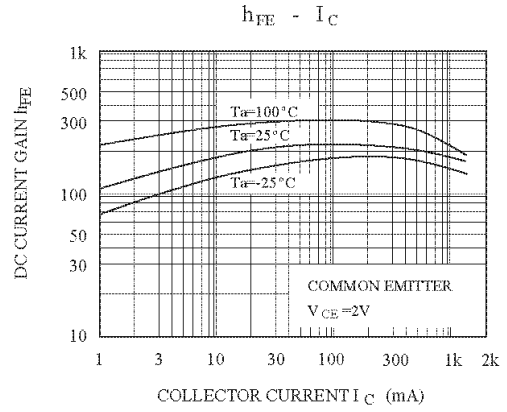
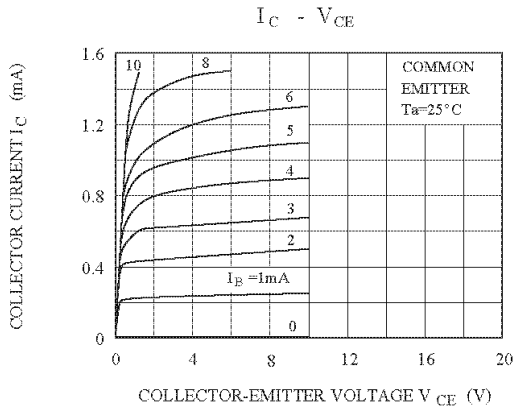

**SEMTECH ELECTRONICS LTD.**  
Subsidiary of Sino-Tech International (BVI) Limited



# ST 2SC4375U

## SOT-89 PACKAGE OUTLINE

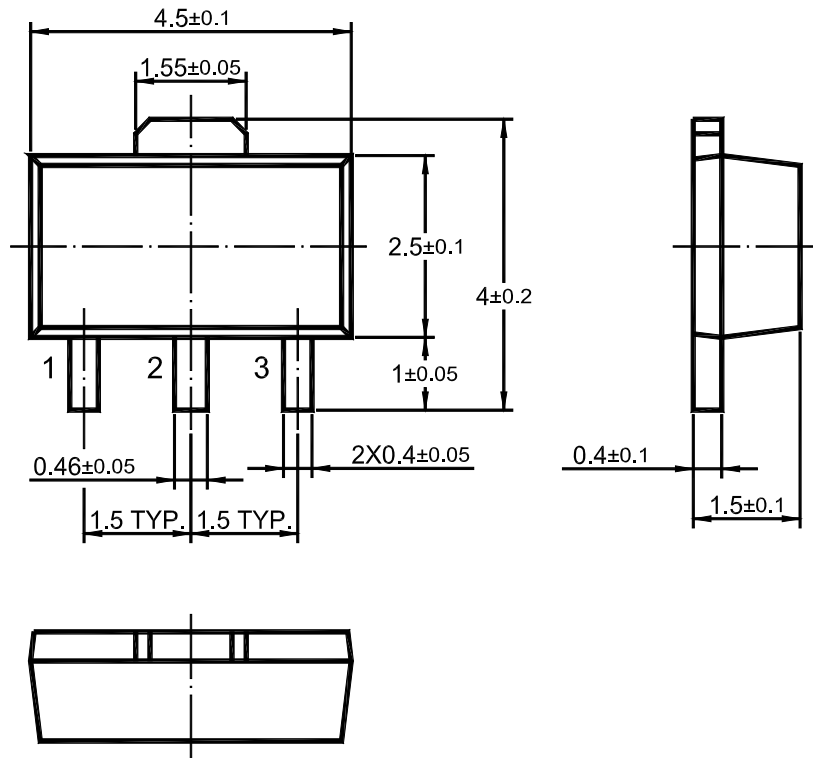

Dimensions in mm

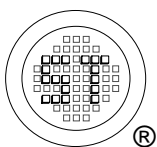

**SEMTECH ELECTRONICS LTD.**  
Subsidiary of Sino-Tech International (BVI) Limited



Dated : 17/04/2007