

ST 2SC2073U

NPN Silicon Epitaxial Planar Transistor

General purpose amplifier and high voltage application

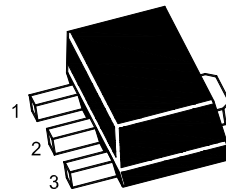

1.Base 2.Collector 3.Emmitter
SOT-89 Plastic Package

Absolute Maximum Ratings ($T_a = 25\text{ }^\circ\text{C}$)

Parameter	Symbol	Value	Unit
Collector Base Voltage	V_{CBO}	160	V
Collector Emitter Voltage	V_{CEO}	160	V
Emitter Base Voltage	V_{EBO}	7	V
Collector Current	I_C	1	A
Peak Collector Current (Single pulse, $t_p = 300\text{ }\mu\text{s}$)	I_{CP}	2	A
Total Power Dissipation	P_{tot}	0.5 1 ¹⁾	W
Junction Temperature	T_j	150	$^\circ\text{C}$
Storage Temperature Range	T_{stg}	- 55 to + 150	$^\circ\text{C}$

¹⁾ mounted on a ceramic substrate (250 mm² X 0.8 t)

Characteristics at $T_a = 25\text{ }^\circ\text{C}$

Parameter	Symbol	Min.	Typ.	Max.	Unit
DC Current Gain at $V_{CE} = 5\text{ V}$, $I_C = 30\text{ mA}$	h_{FE}	200	-	400	-
Collector Base Cutoff Current at $V_{CB} = 160\text{ V}$	I_{CBO}	-	-	0.1	μA
Emitter Base Cutoff Current at $V_{EB} = 4\text{ V}$	I_{EBO}	-	-	0.1	μA
Collector Base Breakdown Voltage at $I_C = 100\text{ }\mu\text{A}$	$V_{(BR)CBO}$	160	-	-	V
Collector Emitter Breakdown Voltage at $I_C = 1\text{ mA}$	$V_{(BR)CEO}$	160	-	-	V
Emitter Base Breakdown Voltage at $I_E = 100\text{ }\mu\text{A}$	$V_{(BR)EBO}$	7	-	-	V
Collector Emitter Saturation Voltage at $I_C = 500\text{ mA}$, $I_B = 50\text{ mA}$ at $I_C = 200\text{ mA}$, $I_B = 2\text{ mA}$	$V_{CE(sat)}$	-	-	0.5 1	V
Base Emitter Saturation Voltage at $I_C = 500\text{ mA}$, $I_B = 50\text{ mA}$	$V_{BE(sat)}$	-	-	1.2	V
Transition Frequency at $V_{CE} = 5\text{ V}$, $I_C = 50\text{ mA}$	f_T	-	150	-	MHz
Collector Output Capacitance at $V_{CB} = 10\text{ V}$, $f = 1\text{ MHz}$	C_{ob}	-	10	-	pF

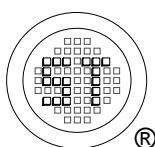

SEMTECH ELECTRONICS LTD.
Subsidiary of Sino-Tech International (BVI) Limited



Dated : 20/07/2011 Rev:01

Fig. 1 $P_C - T_a$

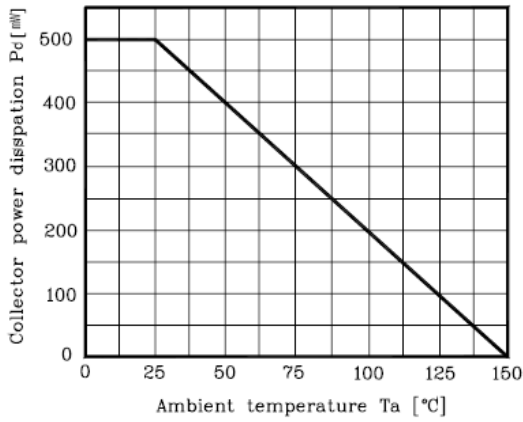

Fig. 2 $I_C - V_{BE}$

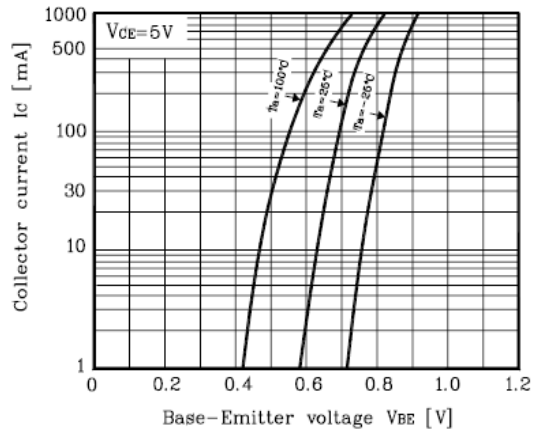

Fig. 3 $V_{CE(sat)} - I_C$

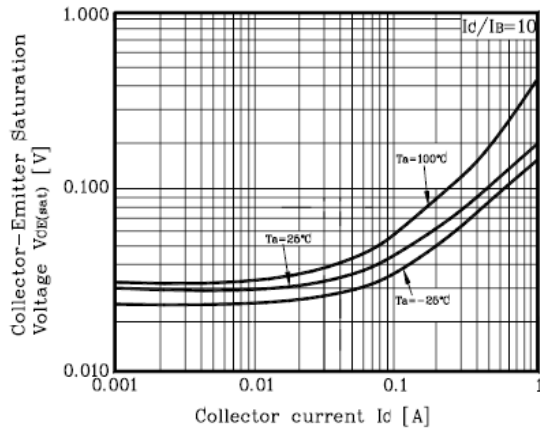

Fig. 4 $I_C - V_{CE}$

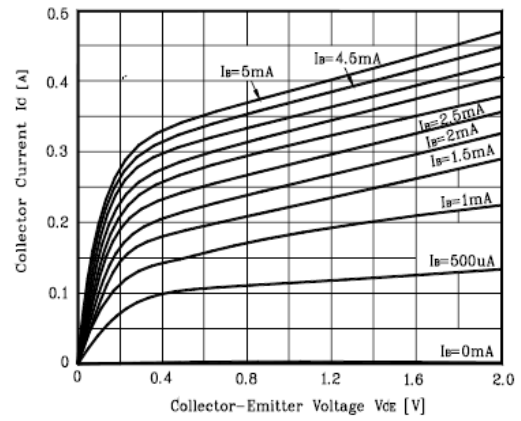

Fig. 5 $I_C - V_{CE}$

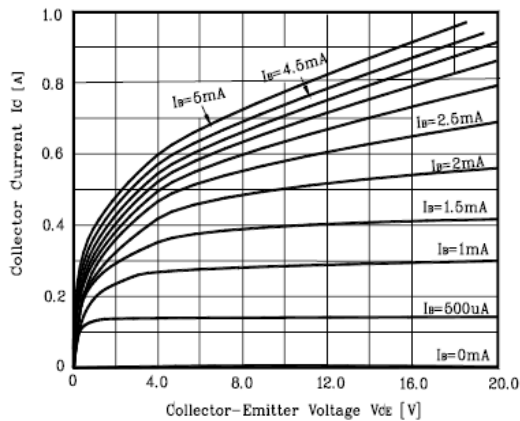
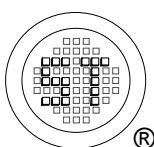
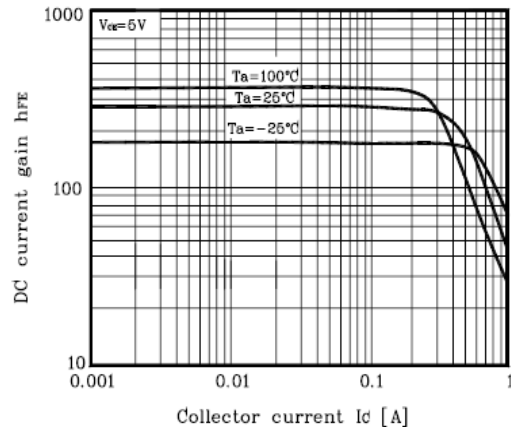
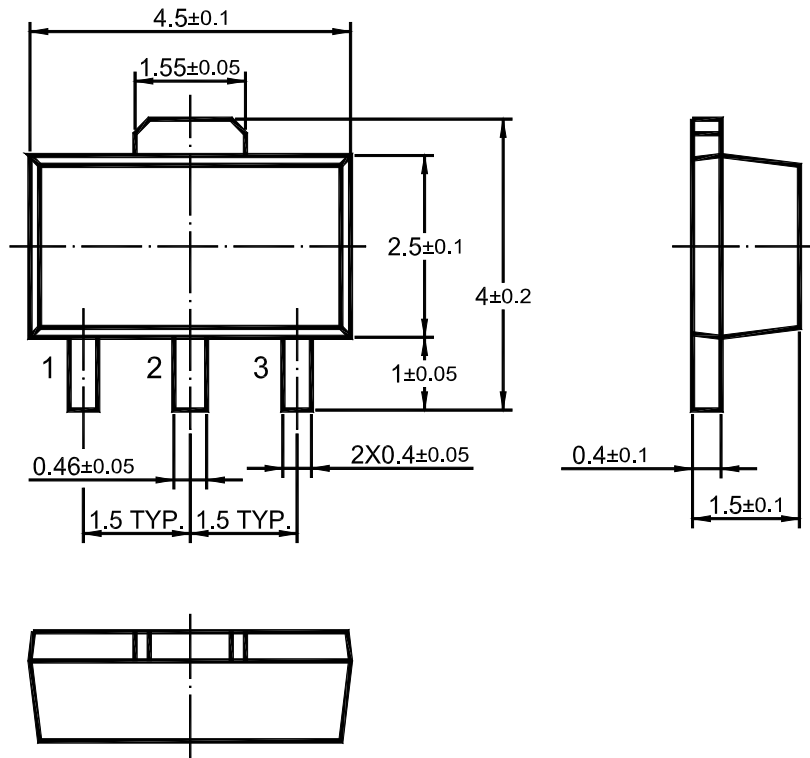

Fig. 6 $h_{FE} - I_C$



ST 2SC2073U

SOT-89 PACKAGE OUTLINE



Dimensions in mm

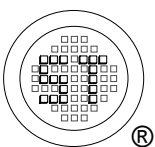

SEMTECH ELECTRONICS LTD.
Subsidiary of Sino-Tech International (BVI) Limited



Dated : 20/07/2011 Rev:01