

# Packaging Specifications of 52 mm Ammo Pack R-1

1. The method of inner box packaging is shown in figure 1.
2. Dimension and quantity of inner box and taping.

Units in mm

Product outline	A	B	C	Quantity	b	c	f	g	h	$ l_1-l_2 $	m
R-1	256	80	140	5 Kpcs / box	52.25 ±0.25	6.25 ±0.25	5.00 ±0.30	1.0 max.	1.0 max.	1.0 max.	0.8 max.

### 3. Carton Dimension

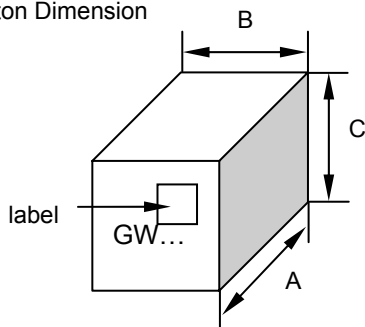

Product outline		R-1
Dimension	A (mm)	430
	B (mm)	309
	C (mm)	325

- 3.1 10 box / carton
- 5 box / layer
- 2 layer / carton

### 4. Quantity of Carton Pack.

Product outline	R-1
Quantity	50 Kpcs

### 5. Label

5.1 The information of inner box label must be listed:

- 5.1.1 TYPE
- 5.1.2 QTY
- 5.1.3 CODE
- 5.1.4 RMK

5.2 The information of carton label must be listed:

- 5.2.1 TYPE
- 5.2.2 QTY

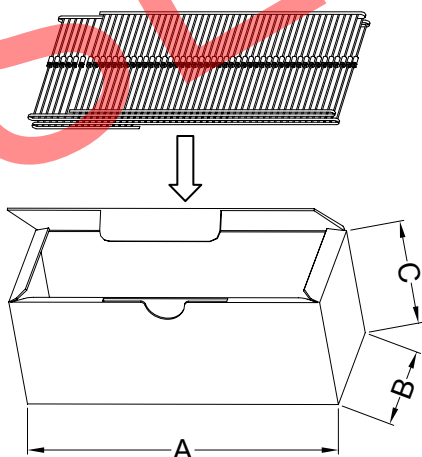
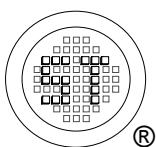
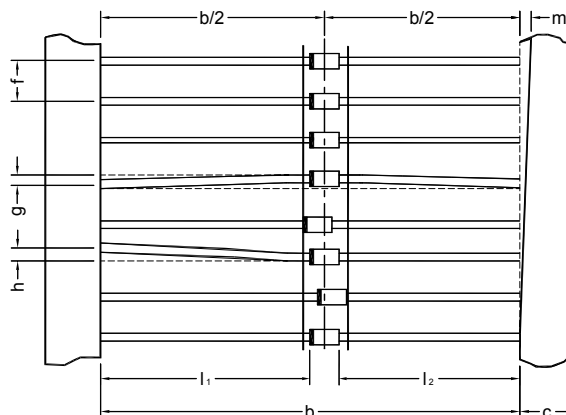

figure 1.



**SEMTECH ELECTRONICS LTD.**  
Subsidiary of Sino-Tech International (BVI) Limited

