

Packaging Specifications of 52 mm Ammo Pack for Lead Type Diodes

1. The method of packaging and dimension are shown as below figure. (Dimension in mm)

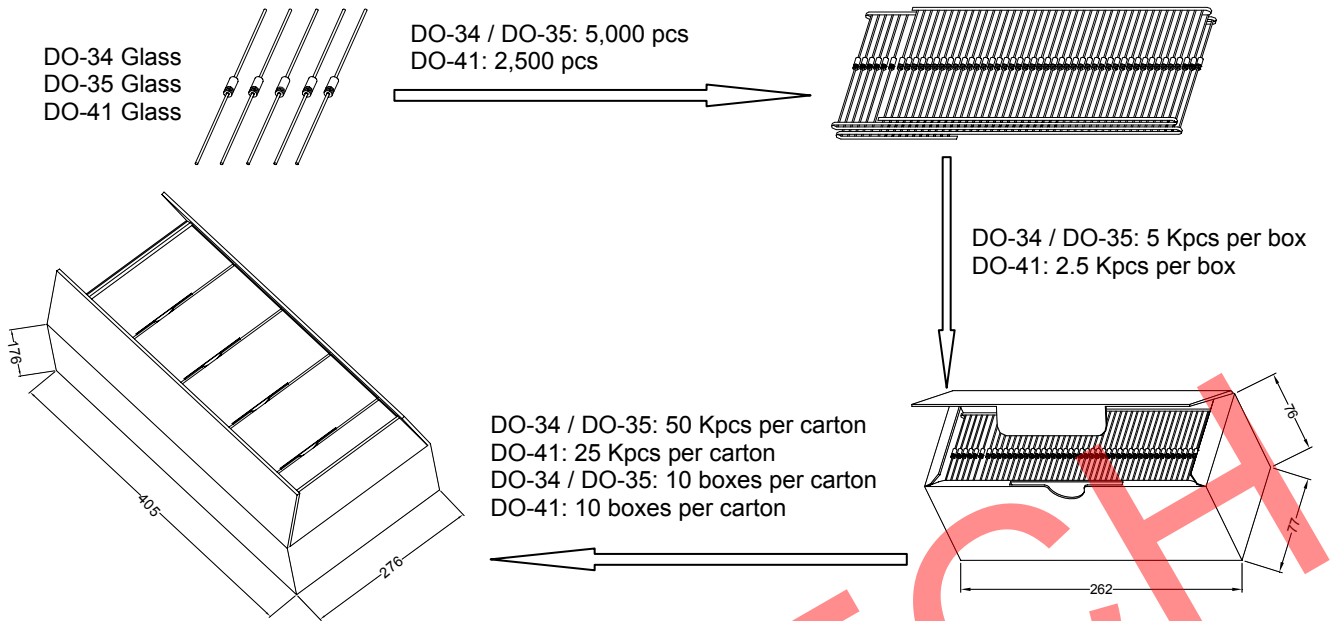

2. Dimension of taping.

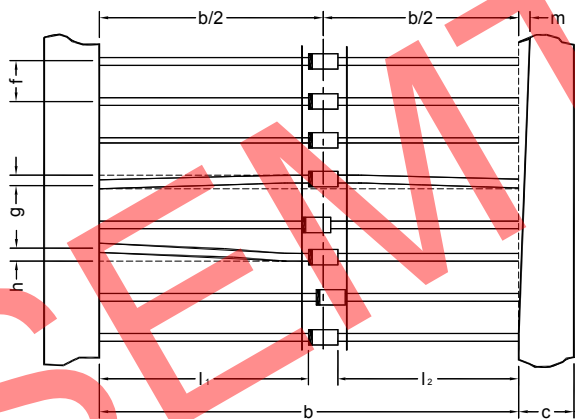

Units in mm

b	52.25 ±0.25
c	6.25 ±0.25
f	5 ±0.3
g	1 max.
h	1 max.
l ₁ -l ₂	1 max.
m	0.8 max.

3. Label

3.1 The information of inner box label must be listed: (Description of a sample lable)

- 3.1.1 **TYPEBZX55C2V0** means (Product) TYPE (Part No.)
- 3.1.2 **QTY 10,000 PCS** means (Product) Quantity (QTY)
- 3.1.3 **D/C TT0C2H0129Z020** means Dice Lot No. / Code (D/C)
- 3.1.4 **P/C 80092032** means Production Code (P/C)
- 3.1.5 **RMK80303 G PX H** = means Manufacturing Date (RMK)

3.2 The information of carton label must be listed:

- 3.2.1 TYPE
- 3.2.2 QTY

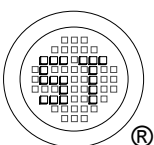

SEMTECH ELECTRONICS LTD.
Subsidiary of Sino-Tech International (BVI) Limited



Packaging Specifications of 52 mm Ammo Pack for Lead Type Diodes

1. The method of inner box packaging is shown in figure 1.
2. Dimension and quantity of inner box and taping.

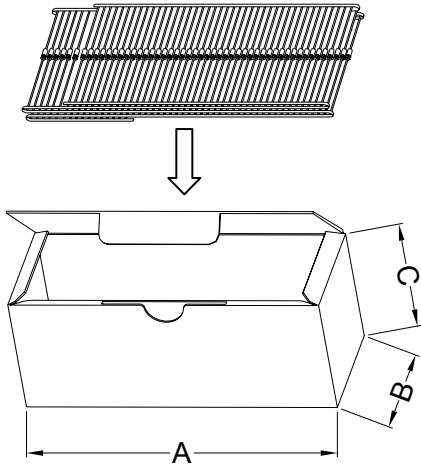
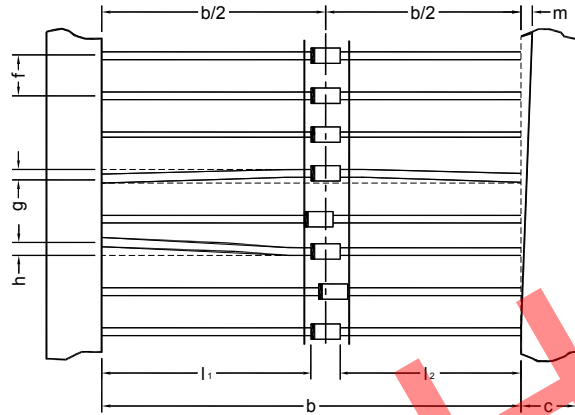

figure 1.



Units in mm

Product Outline	A	B	C	Quantity	b	c	f	g	h	$ l_1-l_2 $	m
DO-7	262	77	71	1.5 Kpcs / Box	52.25 ± 0.25	6.25 ± 0.25	5.0 ± 0.3	1 max.	1 max.	1 max.	0.8 max.
DO-41 (Plastic)	256	75	140	5 Kpcs / Box	52.4 ± 1.5	6.0 ± 0.4	5.0 ± 0.5	1.2 max.	$90^\circ \pm 5^\circ$	1 max.	0.8 max.
DO-15				2 Kpcs / Box							
DO-201AD / DO-27				3 Kpcs / Box							
R-6				250 pcs / Box							

3. Carton Dimension

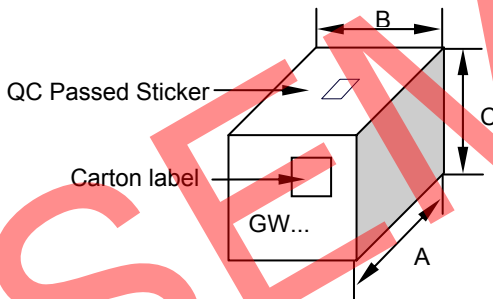

Product outline	DO-7	DO-41 (Plastic)	DO-15	DO-201AD DO-27	R-6
Dimension					
A (mm)	404	420	435	420	435
B (mm)	273	270	270	270	270
C (mm)	165	300	180	300	180

4. Quantity of Carton Pack.

Product outline	DO-7	DO-41 (Plastic)	DO-15	DO-201AD / DO-27	R-6
Quantity	25 Kpcs	50 Kpcs	20 Kpcs	12.5 Kpcs	2.5 Kpcs

5. Label

5.1 The information of inner box label must be listed:

- 5.1.1 TYPE
- 5.1.2 QTY
- 5.1.3 CODE
- 5.1.4 RMK

5.2 The information of carton label must be listed:

- 5.2.1 TYPE
- 5.2.2 QTY

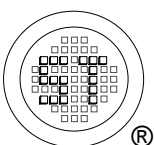

SEMTECH ELECTRONICS LTD.
Subsidiary of Sino-Tech International (BVI) Limited

