

Packaging Specification for Surface Mounted Mold Diodes & Transistors

1. The method of packaging and dimension are shown as below figure. (Dimension in mm)

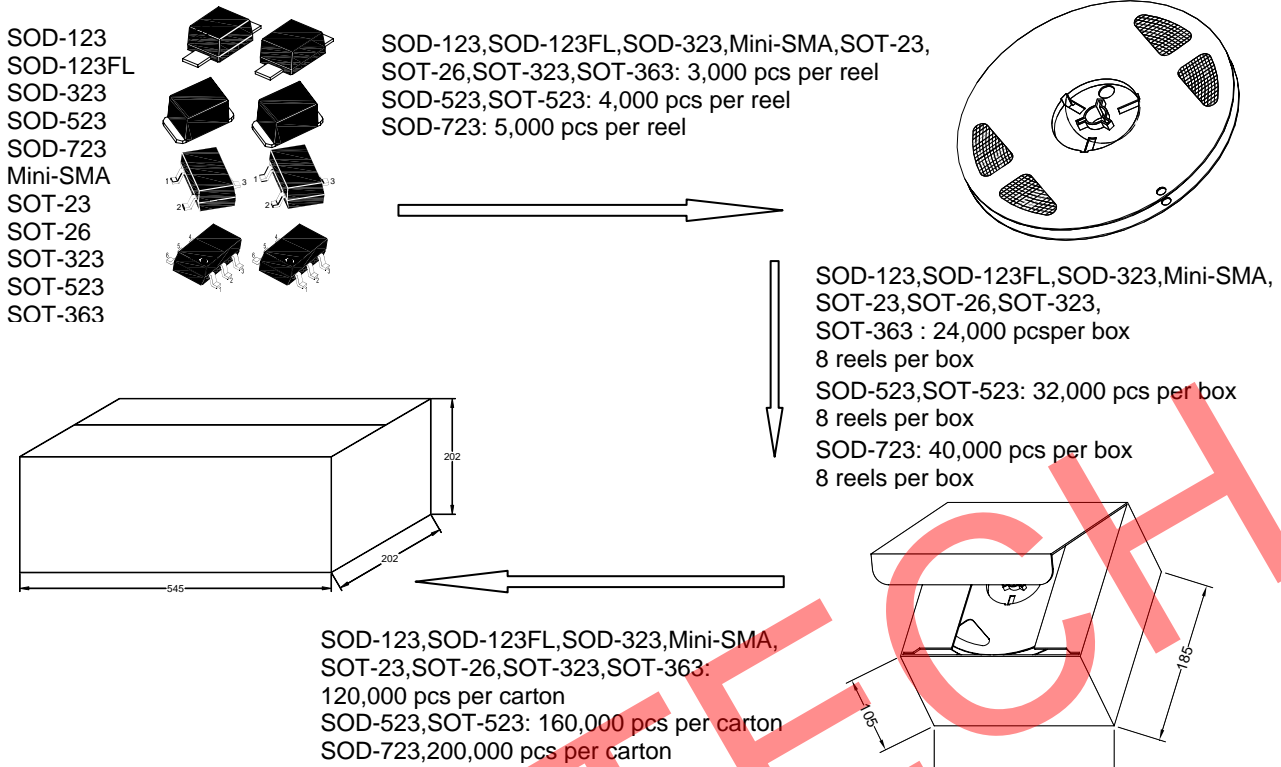

2. Label

2.1 The information of inner box label must be listed: (Description of a sample lable)

- 2.1.1 TYPE **1N4148WT** means (Product) TYPE (Part No.)
- 2.1.2 QTY **32,000 PCS** means (Product) Quantity (QTY)
- 2.1.3 D/C **SLOB6H0107S000-036 -160** means Dice Lot No. / Code (D/C)
- 2.1.4 P/C **C05466-00082** means Production Code (P/C)
- 2.1.5 **RMK 80126 -3 PX** means Manufacturing Date (RMK)

2.2 The information of carton label must be listed:

- 2.2.1 TYPE
- 2.2.2 QTY

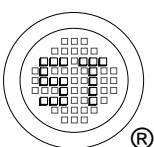

SEMTECH ELECTRONICS LTD.
 Subsidiary of Sino-Tech International (BVI) Limited

