

MBRF2070CT THRU MBRF20100CT

DUAL SCHOTTKY RECTIFIERS

Reverse Voltage - 70 to 100 V

Forward Current - 20 A

ITO-220AB

Features

- High surge capability
- For use in low voltage, high frequency inverters, free wheeling, and polarity protection applications
- Metal silicon junction, majority carrier conduction
- High current capability, low forward voltage drop
- Guard ring for over voltage protection

Mechanical Data

- **Case:** ITO-220AB, molded plastic body
- **Terminals:** Solderable per MIL-STD-750, Method 2026
- **Polarity:** As marked
- **Mounting position:** Any

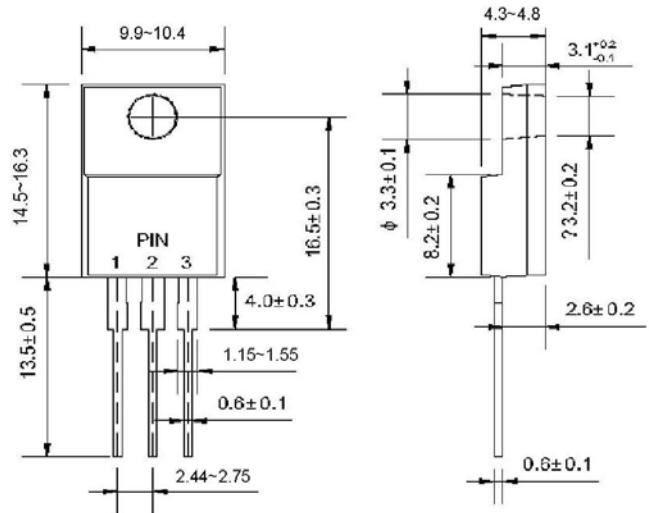

Dimensions in millimeters

Maximum Ratings and Characteristics

Ratings at 25 °C ambient temperature unless otherwise specified.

Parameter	Symbols	MBRF2070CT	MBRF2080CT	MBRF2090CT	MBRF20100CT	Units
Maximum Recurrent Peak Reverse Voltage	V_{RRM}	70	80	90	100	V
Maximum Working Peak Reverse Voltage	V_{RWM}	49	56	63	70	V
Maximum DC Blocking Voltage	V_{DC}	70	80	90	100	V
Maximum Average Forward Rectified Current at $T_C = 133\text{ }^\circ\text{C}$	$I_{F(AV)}$	20				A
Peak Forward Surge Current 8.3 ms Single Half Sine Wave Superimposed on Rated Load	I_{FSM}	150				A
Maximum Forward Voltage per Leg ¹⁾	V_F	at $I_F = 10\text{ A}, T_C = 25\text{ }^\circ\text{C}$ 0.8 at $I_F = 10\text{ A}, T_C = 125\text{ }^\circ\text{C}$ 0.7 at $I_F = 20\text{ A}, T_C = 25\text{ }^\circ\text{C}$ 0.95 at $I_F = 20\text{ A}, T_C = 125\text{ }^\circ\text{C}$ 0.85				V
Maximum DC Reverse Current at Rated DC Blocking Voltage	I_R	at $T_A = 25\text{ }^\circ\text{C}$ 0.1 at $T_A = 125\text{ }^\circ\text{C}$ 6				mA
Maximum Junction Capacitance ²⁾	C_J	400				pF
Operating Junction Temperature Range	T_j	- 55 to + 150				°C
Storage Temperature Range	T_{stg}	- 55 to + 175				°C

¹⁾ Pulse test: 300 μs pulse width, 1% duty cycle.

²⁾ $V_R = 5\text{ V}$ (test signal range 100 KHz to 1 MHz)

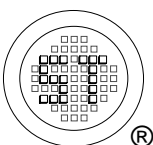

SEMTECH ELECTRONICS LTD.
Subsidiary of Sino-Tech International (BVI) Limited



MBRF2070CT THRU MBRF20100CT

FIG.1 – FORWARD CURRENT DERATING CURVE

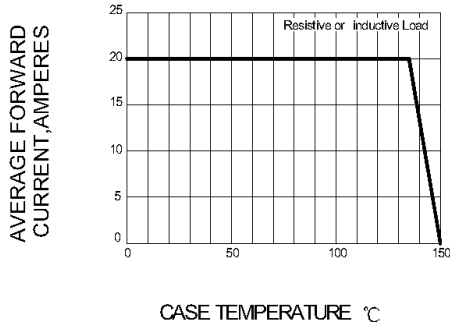

FIG.2 – MAXIMUM NON-REPETITIVE PEAK FORWARD SURGE CURRENT PER LEG

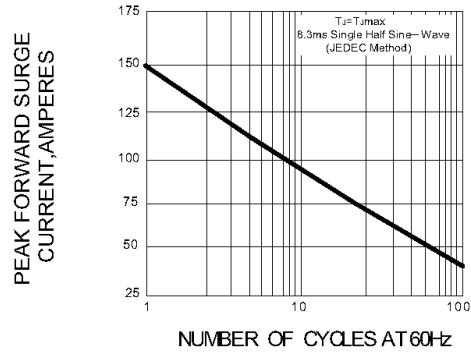

FIG.3 – TYPICAL INSTANTANEOUS FORWARD CHARACTERISTICS PER LEG

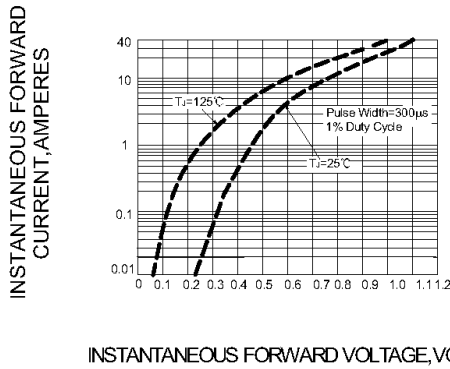

FIG.4 – TYPICAL REVERSE CHARACTERISTICS PER LEG

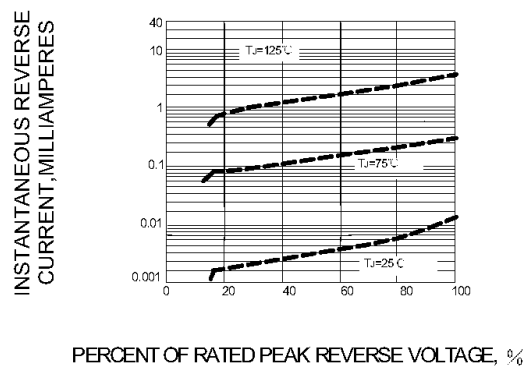
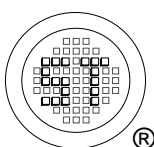
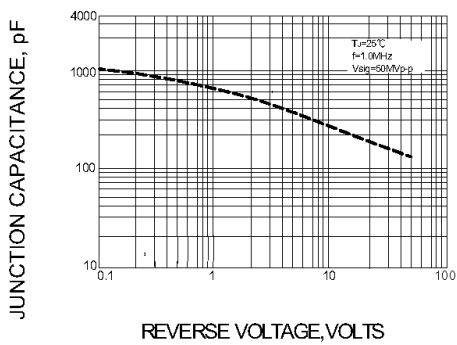

FIG.5 – TYPICAL JUNCTION CAPACITANCE PER LEG



SEMTECH ELECTRONICS LTD.
Subsidiary of Sino-Tech International (BVI) Limited

