

BAT48WS

Schottky Barrier Diode

Features

- Low forward voltage
- Small plastic SMD SOD-323 package

PINNING

PIN	DESCRIPTION
1	Cathode
2	Anode

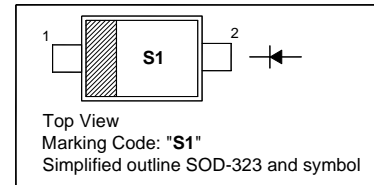

Absolute Maximum Ratings ($T_a = 25\text{ }^\circ\text{C}$)

Parameter	Symbol	Value	Unit
Repetitive Peak Reverse Voltage	V_{RRM}	40	V
Forward Current	I_F	350	mA
Peak Forward Surge Current ($t_p = 10\text{ ms}$)	I_{FSM}	2	A
Thermal Resistance from Junction Ambient	R_{thJA}	550	$^\circ\text{C/W}$
Maximum Operating Junction Temperature	T_j	150	$^\circ\text{C}$
Storage Temperature Range	T_{stg}	- 65 to + 150	$^\circ\text{C}$

Characteristics at $T_a = 25\text{ }^\circ\text{C}$

Parameter	Symbol	Min.	Max.	Unit
Reverse Breakdown Voltage at $I_R = 25\text{ }\mu\text{A}$	$V_{(BR)R}$	40	-	V
Forward Voltage at $I_F = 0.1\text{ mA}$ at $I_F = 1\text{ mA}$ at $I_F = 10\text{ mA}$ at $I_F = 50\text{ mA}$ at $I_F = 200\text{ mA}$ at $I_F = 500\text{ mA}$	V_F	- - - - - -	0.25 0.3 0.4 0.5 0.75 0.9	V
Reverse Current at $V_R = 1.5\text{ V}$ at $V_R = 10\text{ V}$ at $V_R = 20\text{ V}$ at $V_R = 40\text{ V}$	I_R	- - - -	1 2 5 25	μA

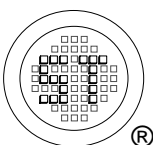

SEMTECH ELECTRONICS LTD.
Subsidiary of Sino-Tech International (BVI) Limited



Dated : 09/06/2009

BAT48WS

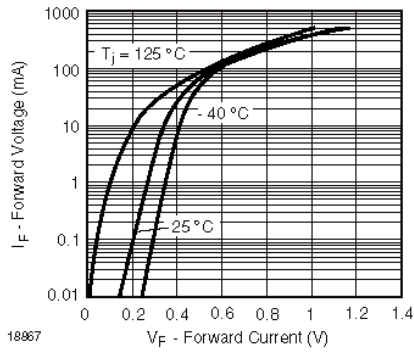

Figure 1. Typical Forward Voltage Forward Current at Various Temperatures

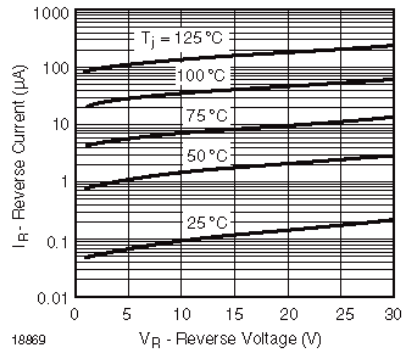

Figure 3. Typical Variation of Reverse Current at Various Temperatures

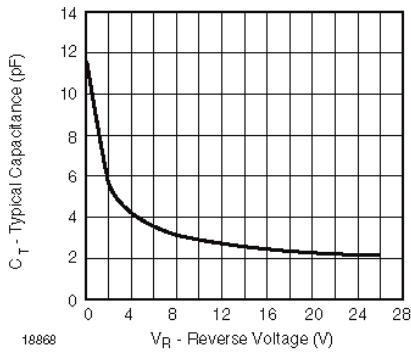
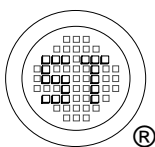

Figure 2. Typical Capacitance C_T vs. Reverse Applied Voltage V_R



SEMTECH ELECTRONICS LTD.
 Subsidiary of Sino-Tech International (BVI) Limited



Dated : 09/06/2009

BAT48WS

PACKAGE OUTLINE

Plastic surface mounted package; 2 leads

SOD-323

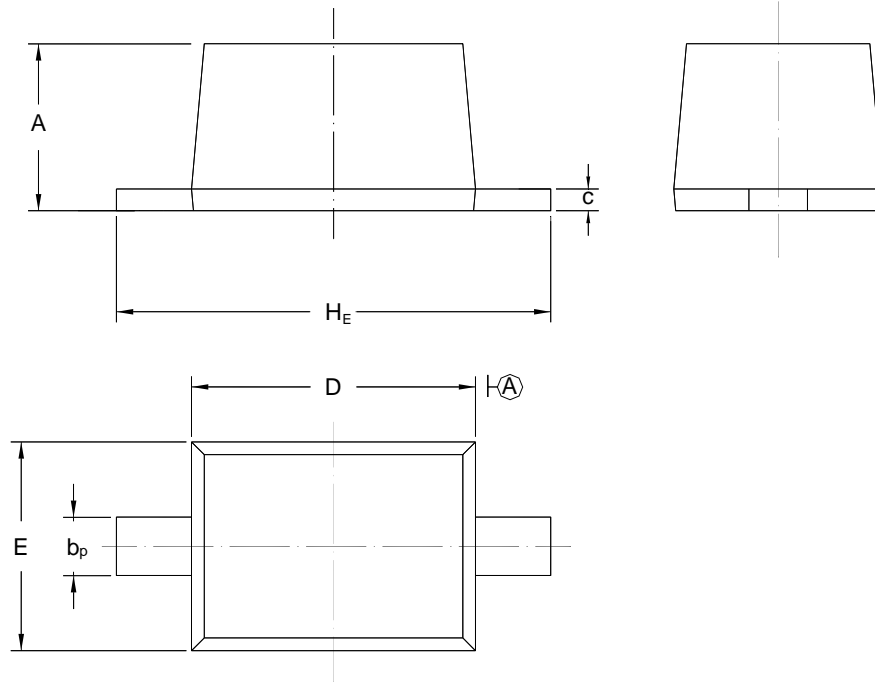

UNIT	A	b _p	C	D	E	H _E
mm	1.10 0.80	0.40 0.25	0.15 0.10	1.80 1.60	1.35 1.15	2.80 2.30

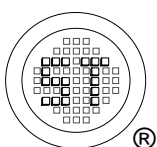

SEMTECH ELECTRONICS LTD.
Subsidiary of Sino-Tech International (BVI) Limited



Dated : 09/06/2009